

VSRRX Quad Reverse Receiver

Description



The VSRRX is a Quad analog return path receiver. Its compact design makes it one of the highest density packaging available in the market. It allows the operator to install 4 return path receivers in one 1RU chassis. The output power is approximately 45dBmV for the VSRRX and this will allow passive RF splitting, saving rack space and increasing reliability. This compact design minimizes rack space requirements in the head-end and hubs, and enhances deployment of traditional HFC, passive HFC and fiber to the home (FTTH) networks.

Specifications

Parameter	Unit	Specification	Note
Optical Performance			
Wavelength	nm	1200-1600	--
Input port		4	--
Input power	dBm	-18 to 0	--
Connector		SC/APC	--
RF Performance			
Bandwidth	MHz	5-200	--
Return loss	-dB	≥16	--
Flatness	dB	+/-1	--
Impedance	ohm	75	--
Output level	dBmV	≥45	1
Test point	dB	-20+/-1	--
CNR	dB	≥48	1
CSO	-dBc	≥55	2
CTB	-dBc	≥60	2
MGC	dB	0 to -20	--
Connector		F-female	--
Electrical/Physical Performance			
Supply voltage	VAC	90-260	50/60Hz
Power consumption	W	<18	--
Dimensions	mm	389D x 483W x 44H	--
Weight	Kg	4.5	--

1.-7dBm optical input , OMI=16% , 0dB attenuation setting
 2.45dBmV output , two tone test , f1=13MHz , f2=19MHz

Features

- 5 to 200MHz bandwidth
- 19" standard 1U rack design
- Wide dynamic optical input range: -18 to 0dBm
- High RF output: 45dBmV
- High packaging density (up to 4 receivers per chassis)
- Front access -20dB output test points
- Wink switch for ingress troubleshooting
- LED status indicator lights

Dimensions [Unit:mm]

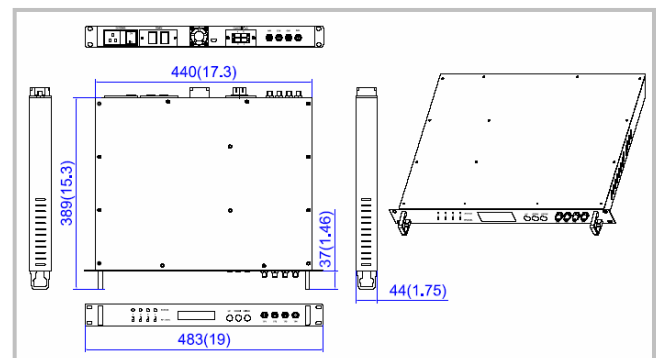

Absolute Maximum Ratings

Stresses in excess of the absolute maximum ratings can cause permanent damage to the device. These are absolute stress ratings only. Functional operation of the device is not implied at these conditions. Exposure to absolute maximum ratings for extended periods can adversely affect device reliability.

Parameter	Symbol	Unit	Min	Max
Operating temperature	Top	°C	0	50
Storage temperature	Tstg	°C	-20	70
Humidity	H	%		85, non-condensing

Block Diagram

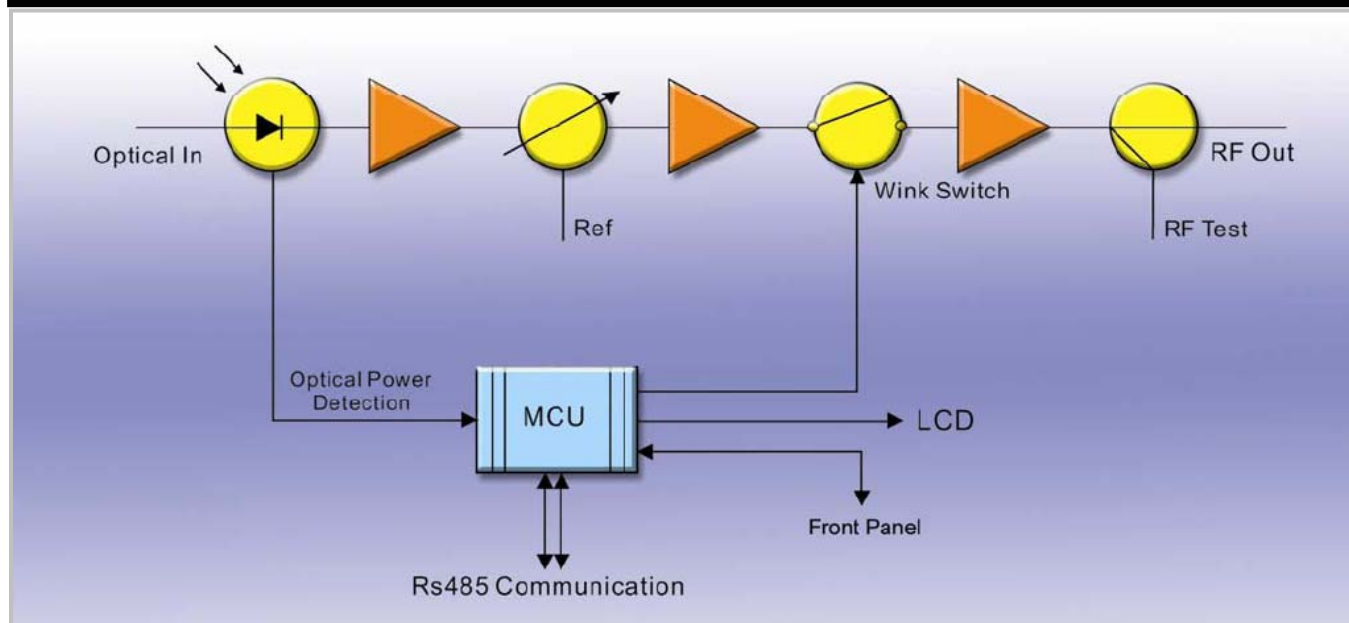

Ordering Information

VSRRX	--	45	--	XX	--	XX
				Connector : SA = SC/APC FA = FC/APC		Customer specify